

---

## 3A Boost Converter for High Brightness LED Driver with Multiple Dimming Methods

---

### FEATURES

- 2.9-V to 18-V Input Voltage Range
- 3-A, 40-V Internal Power Switch
  - Four 3-W LEDs from 5-V input
  - Eight 3-W LEDs from 12-V input
- High Efficiency Power Conversion: Up to 93%
- Frequency Set by External Resistor: 200-kHz to 2.2-MHz
- User Defined Soft Start into Full Load

- Programmable over voltage protection
- Analog and Pure PWM Brightness Dimming
- 14-pin HTSSOP Package with PowerPad

### APPLICATIONS

- Monitor backlight
- 1-W or 3-W high brightness LED

### DESCRIPTION

The TPS61500 is a monolithic switching regulator with integrated 3-A, 40-V power switch. It is an ideal driver for high brightness 1-W or 3-W LED. The device has a wide input voltage range to support application with input voltage from multi-cell batteries or regulated 5-V, 12-V power rails.

The LED current is set with an external sensor resistor R3, and the feedback voltage that is regulated to 200-mV by current mode PWM (pulse width modulation) control loop, as shown in the typical application. The device supports analog and pure PWM dimming methods for LED brightness control. Connecting a capacitor to the DIMC pin configures the device to be used for analog dimming, and the LED current varies proportional to the duty cycle of an external PWM signal. Floating the DIMC pin configures the IC for pure PWM dimming with the average LED current being the PWM signal's duty cycle times a set LED current.

The device features a programmable soft-start function to limit inrush current during start-up, and has built-in other protection features, such as pulse-by-pulse over current limit, over voltage protection and thermal shutdown. The TPS61500 is available in 14-pin HTSSOP package with PowerPad.



Please be aware that an important notice concerning availability, standard warranty, and use in critical applications of Texas Instruments semiconductor products and disclaimers thereto appears at the end of this data sheet.



These devices have limited built-in ESD protection. The leads should be shorted together or the device placed in conductive foam during storage or handling to prevent electrostatic damage to the MOS gates.

**TYPICAL APPLICATION**

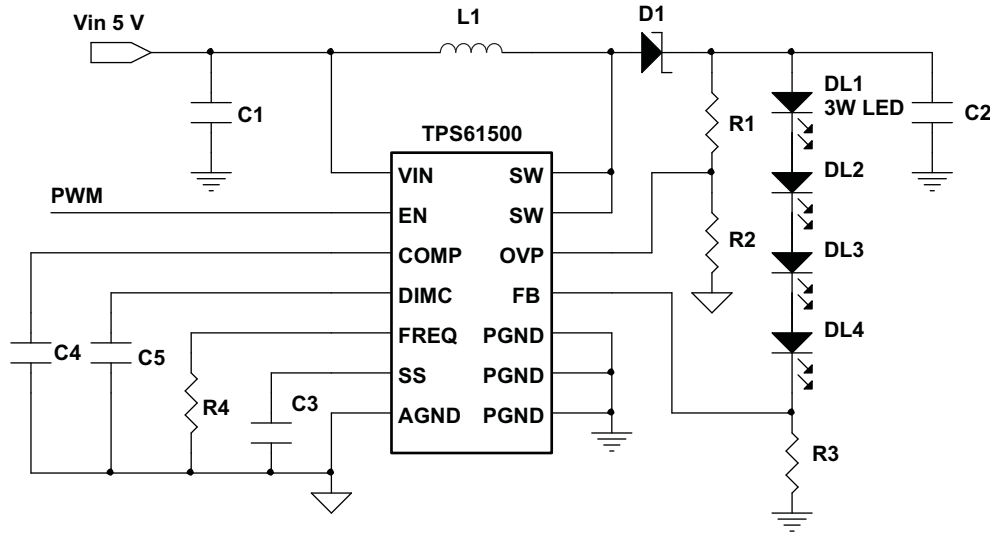

**Figure 1. Analog Dimming Method**

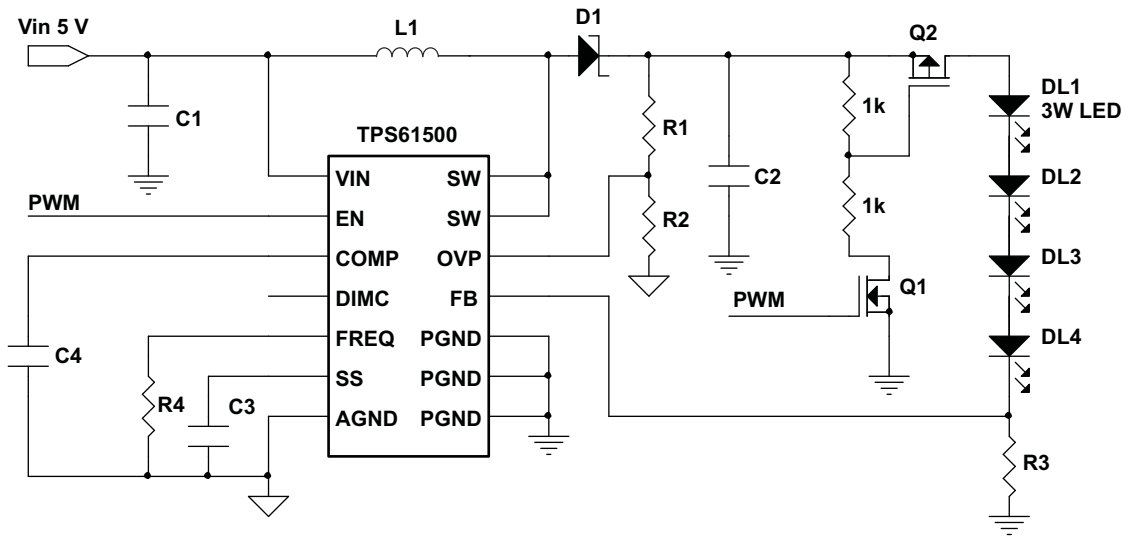

**Figure 2. Pure PWM Dimming Method**

**ORDERING INFORMATION<sup>(1)(2)</sup>**

T <sub>A</sub>	PART NUMBER	PACKAGE	PACKAGE MARKING
-40°C to 85°C	TPS61500	HTSSOP-14	TPS61500PWP

- (1) For the most current package and ordering information, see the TI WEB site at [www.ti.com](http://www.ti.com)
- (2) The PWP package is available in tape and reel. Add R suffix (TPS61500PWPR) to order quantities of 2000 parts per reel. Without suffix, the TPS61500PWP is shipped in tubes with 90 parts per tube.

## ABSOLUTE MAXIMUM RATINGS<sup>(1)</sup>

over operating free-air temperature range (unless otherwise noted)

	VALUE	UNIT
Supply voltages on pin VIN <sup>(2)</sup>	–0.3 to 20	V
Voltages on pins EN <sup>(2)</sup>	–0.3 to 20	V
Voltage on pin FB, FREQ and COMP, OVP <sup>(2)</sup>	–0.3 to 3	V
Voltage on pin DIMC, SS <sup>(2)</sup>	–0.3 to 7	V
Voltage on pin SW <sup>(2)</sup>	–0.3 to 40	V
Continuous power dissipation	See Dissipation Rating Table	
Operating junction temperature range	–40 to 150	°C
Storage temperature range	–65 to 150	°C
Lead temperature (soldering, 10 sec)	260	°C

- (1) Stresses beyond those listed under *absolute maximum ratings* may cause permanent damage to the device. These are stress ratings only and functional operation of the device at these or any other conditions beyond those indicated under *recommended operating conditions* is not implied. Exposure to absolute-maximum-rated conditions for extended periods may affect device reliability.
- (2) All voltage values are with respect to network ground terminal.

## DISSIPATION RATINGS

PACKAGE	THERMAL RESISTANCE R <sub>θJA</sub>	T <sub>A</sub> ≤ 25°C POWER RATING	T <sub>A</sub> = 85°C POWER RATING
14 pin PWP <sup>(1)</sup>	44.5 °C/W	2.25W	0.9W

- (1) Rating based on JEDEC high thermal conductivity (High K) board with 2x2 array of thermal vias. See Texas Instruments application report (SLMA002) regarding thermal characteristics of the PowerPAD package.

## RECOMMENDED OPERATING CONDITIONS

		MIN	NOM	MAX	UNIT
V <sub>IN</sub>	Input voltage range	2.9		18	V
V <sub>O</sub>	Output voltage range	V <sub>IN</sub>		38	V
L	Inductor <sup>(1)</sup>	4.7		47	μH
C <sub>I</sub>	Input Capacitor	4.7		--	μF
C <sub>O</sub>	Output Capacitor	4.7		10	μF
C <sub>dim</sub>	Analog dimming capacitor <sup>(2)</sup>	0.1		--	μF
PWM	Analog and PWM dimming frequency <sup>(3)</sup>	200		1000	Hz
T <sub>A</sub>	Operating ambient temperature	–40		85	°C
T <sub>J</sub>	Operating junction temperature	–40		125	°C

- (1) The inductance value depends on the switching frequency and end applications. While larger values may be used, values between 4.7μH and 47μH have been successfully tested in various applications. Refer to the Inductor Selection for detail.
- (2) The C<sub>dim</sub> with the internal resistor (25kΩ TYP) forms a RC filter that generates the FB reference voltage according to the duty cycle of PWM signal. To optimize the RC filter and reduce the output ripple, the value larger than 0.1μF of C<sub>dim</sub> is recommended.
- (3) When analog dimming, the max PWM frequency is set by on the RC filter to optimize the output ripple. When PWM dimming, the PWM frequency is set by the IC loop response.

## ELECTRICAL CHARACTERISTICS

FSW = 1.2MHz(Rfreq=80kΩ), Vin=3.6V, CRTL=Vin, T<sub>A</sub> = -40°C to 85°C, typical values are at T<sub>A</sub> = 25°C (unless otherwise noted)

PARAMETER		TEST CONDITIONS	MIN	TYP	MAX	UNIT
<b>SUPPLY CURRENT</b>						
V <sub>IN</sub>	Input voltage range		2.9		18	V
I <sub>Q</sub>	Operating quiescent current into Vin	Device PWM switching without load, Vin = 3.6V			3.5	mA
I <sub>SD</sub>	Shutdown current	EN = GND, Vin = 3.6 V			1.5	μA
V <sub>UVLO</sub>	Under-voltage lockout threshold	V <sub>IN</sub> falling		2.5	2.7	V
V <sub>hys</sub>	Under-voltage lockout hysteresis			130		mV
<b>ENABLE AND REFERENCE CONTROL</b>						
V <sub>enh</sub>	EN logic high voltage	Vin = 2.9 V to 18 V	1.2			V
V <sub>enl</sub>	EN logic low voltage	Vin = 2.9 V to 18 V			0.4	V
R <sub>en</sub>	EN pull down resistor		400	800	1600	kΩ
T <sub>off</sub>	Shutdown delay, SS discharge	EN high to low	10			ms
<b>VOLTAGE AND CURRENT CONTROL</b>						
V <sub>REF</sub>	Voltage feedback regulation voltage		195	200	205	mV
I <sub>FB</sub>	Voltage feedback input bias current				200	nA
V <sub>EA_OFF</sub>	Error amplifier offset		-10	0	10	mV
I <sub>sink</sub>	Comp pin sink current	V <sub>FB</sub> = V <sub>REF</sub> +200 mV, V <sub>COMP</sub> = 1 V		40		μA
I <sub>source</sub>	Comp pin source current	V <sub>FB</sub> = V <sub>REF</sub> -200 mV, V <sub>COMP</sub> = 1 V		40		μA
V <sub>CCLP</sub>	Comp pin Clamp Voltage	High Clamp Low Clamp		3 0.75		V
V <sub>CTH</sub>	Comp pin threshold	Duty cycle = 0%		0.95		V
G <sub>ea</sub>	Error amplifier transconductance		240	340	440	μmho
R <sub>ea</sub>	Error amplifier output resistance			10		MΩ
f <sub>ea</sub>	Error amplifier crossover frequency			500		kHz
<b>FREQUENCY</b>						
f <sub>S</sub>	Oscillator frequency	Rfreq = 480 kΩ Rfreq = 80 kΩ Rfreq = 40 kΩ	0.16 1.0 1.76	0.21 1.2 2.2	0.26 1.4 2.64	MHz
D <sub>max</sub>	Maximum duty cycle	Rfreq = 80 kΩ	89%	93%		
V <sub>FREQ</sub>	FREQ pin voltage			1.229		V
T <sub>min_on</sub>	Minimum on pulse width	Rfreq = 80 kΩ		60		ns
R <sub>dim_fil</sub>	Dimming filter resistance			25		kΩ
<b>POWER SWITCH</b>						
R <sub>DS(ON)</sub>	N-channel MOSFET on-resistance	V <sub>IN</sub> = V <sub>GS</sub> = 3.6 V V <sub>IN</sub> = V <sub>GS</sub> = 3.0 V		0.13	0.25 0.3	Ω
I <sub>LN_NFET</sub>	N-channel leakage current	V <sub>DS</sub> = 40 V, T <sub>A</sub> = 25°C			1	μA
<b>OC, OVP and SS</b>						
I <sub>LIM</sub>	N-Channel MOSFET current limit	D = D <sub>max</sub>	3	3.8	5	A
I <sub>SS</sub>	Soft start bias current	V <sub>SS</sub> = 0 V		6		μA
V <sub>OVP</sub>	Over voltage protection threshold		1.192	1.229	1.266	V
V <sub>OVP_hys</sub>	Over voltage protection hysteresis			40		mV
<b>THERMAL SHUTDOWN</b>						
T <sub>shutdown</sub>	Thermal shutdown threshold			160		°C
T <sub>hysteresis</sub>	Thermal shutdown threshold hysteresis			15		°C

## DEVICE INFORMATION

### PIN ASSIGNMENTS

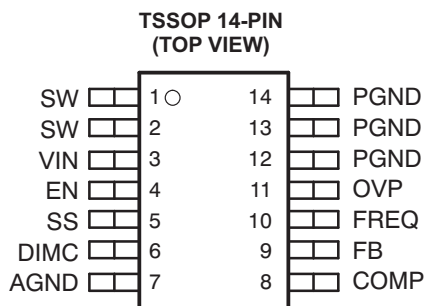

### PIN FUNCTIONS

PIN		I/O	DESCRIPTION
NAME	NO.		
VIN	3	I	The input pin to the IC. Connect VIN to a supply voltage between 2.9V and 18V. It is acceptable for the voltage on the pin to be different from the boost power stage input for applications requiring voltage beyond VIN range.
SW	1,2	I	This is the switching node of the IC. Connect SW to the switched side of the inductor.
FB	9	I	Feedback pin for positive voltage regulation. A resistor connects to this pin to program LED current.
EN	4	I	Enable pin. When the voltage of this pin falls below the enable threshold for more than 10ms, the IC turns off. This pin is also used for PWM signal input for LED brightness dimming.
Comp	8	O	Output of the transconductance error amplifier. An external RC network is connected to this pin.
SS	5	O	Soft start programming pin. A capacitor between the SS pin and GND pin programs soft start timing. See application section for information on how to size the SS capacitor
FREQ	10	O	Switch frequency program pin. An external resistor is connected to this pin. See application section for information on how to size the FREQ resistor.
AGND	7	I	Signal ground of the IC
PGND	12–14	I	Power ground of the IC. It is connected to the source of the PWM switch.
OVP	11	I	Over voltage protection for LED driver. The voltage is 1.229. Using a resistor divider can program the threshold of OVP.
DIMC	6	I	Analog and PWM dimming method option pin. A capacitor connected to the pin to set the time constant of reference for analog dimming. Float this pin for PWM dimming.
Thermal Pad			The thermal pad should be soldered to the analog ground. If possible, use thermal via to connect to top and internal ground plane layers for ideal power dissipation.

FUNCTIONAL BLOCK DIAGRAM

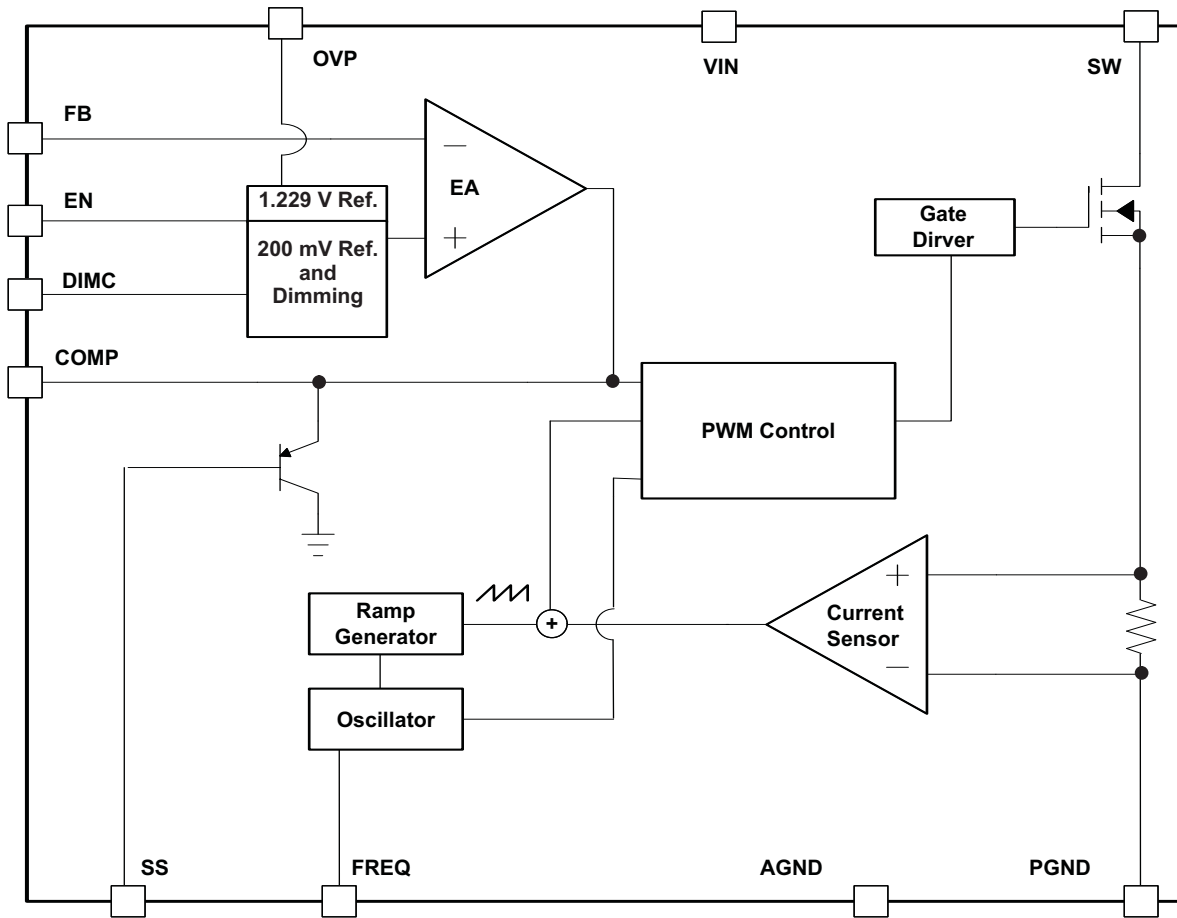

TYPICAL CHARACTERISTICS

TABLE OF GRAPHS

Circuit of Figure 1; L1 = D104C2-10 $\mu$ H; D1 = SS3P6L-E3/86A, R4 = 80k $\Omega$ , C4 = 470nF, C2 = 10 $\mu$ F, LED = OSRAM LCW W5SM, ILED=400mA; unless otherwise noted		FIGURE
Efficiency	VIN = 5 V, 4 LEDs, 8 LEDs, 10 LEDs	3
Efficiency	VIN = 5 V, 12 V; Vout = 8 LEDs	4
FB voltage accuracy	vs Temperature	5
Switch current limit	vs Duty cycle	6
Switch current limit	vs Temperature	7
PWM dimming	VIN = 5 V, 4 LEDs	8
PWM dimming linearity		9
Analog dimming	C5 = 1 $\mu$ F, VIN = 5 V, 4 LEDs	10
Analog dimming linearity		11
PWM dimming start-up	C3 = 47 nF, C5 = Float, 200 Hz with 90% duty cycle	12
Analog dimming start-up	C3 = 47 nF, C5 = 1 $\mu$ F, 5k PWM with 90% duty cycle	13

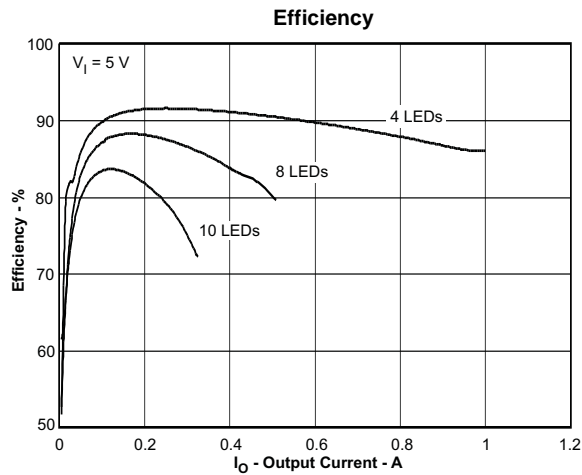

Figure 3.

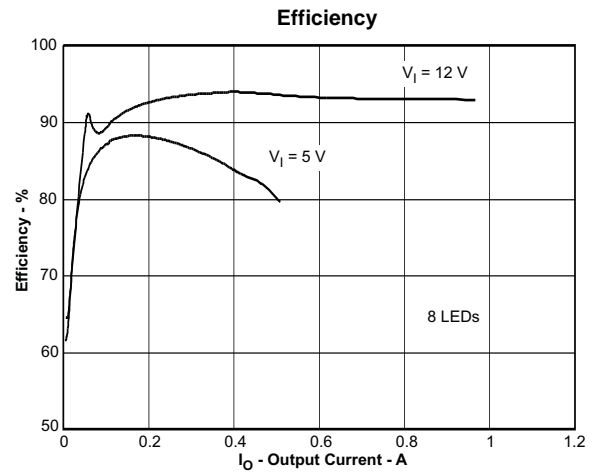

Figure 4.

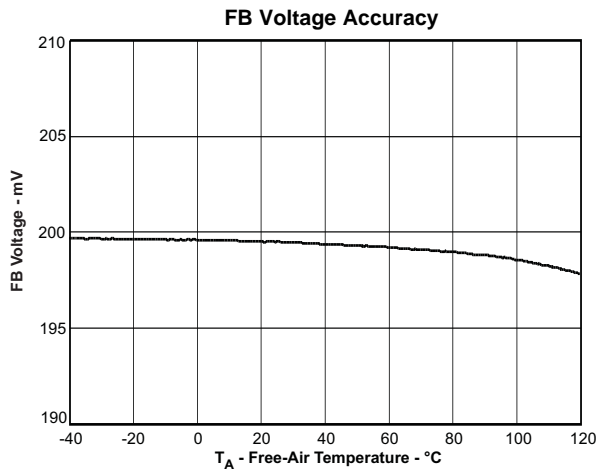

Figure 5.

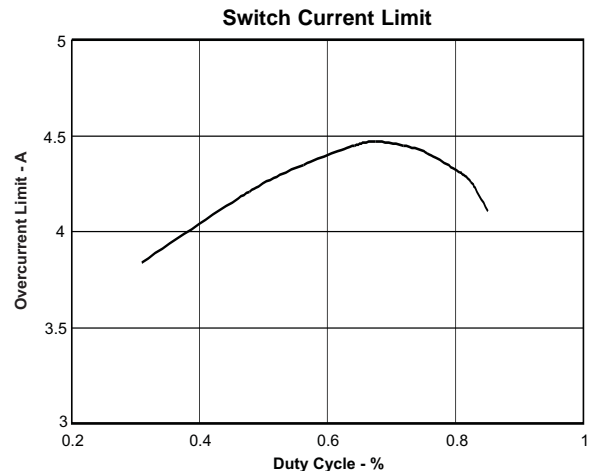

Figure 6.

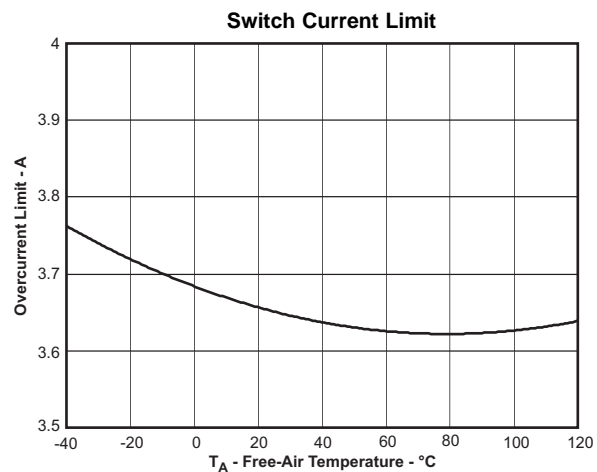

Figure 7.

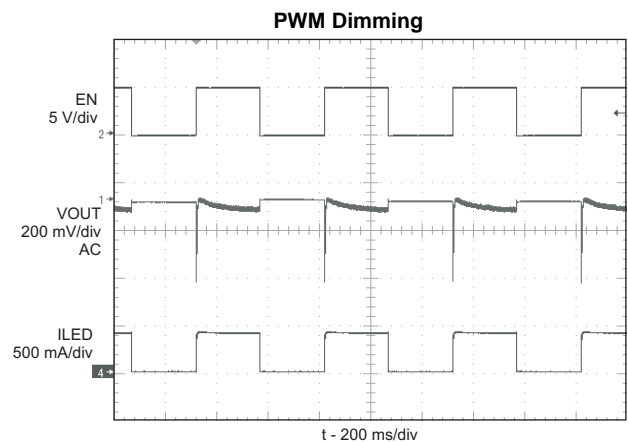

Figure 8.

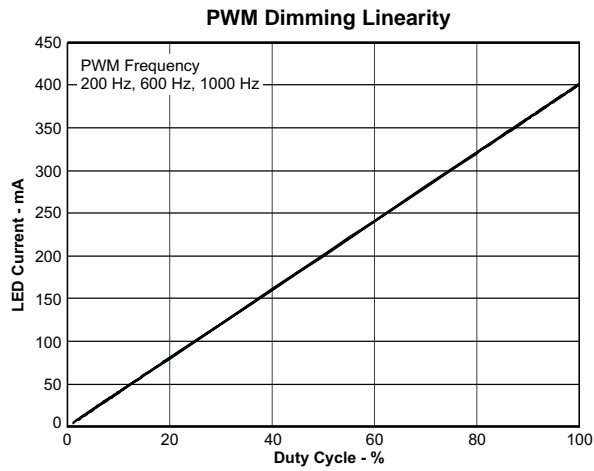

Figure 9.

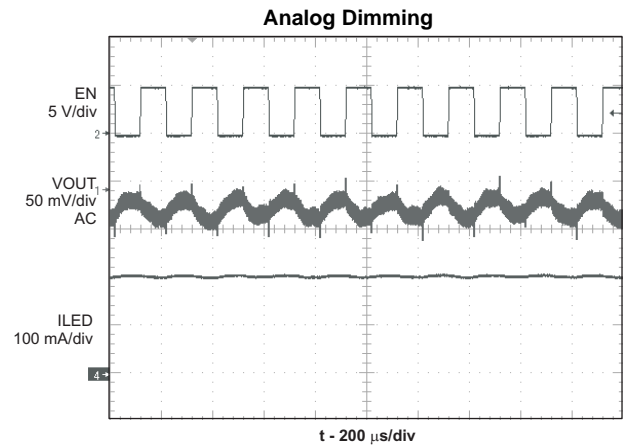

Figure 10.

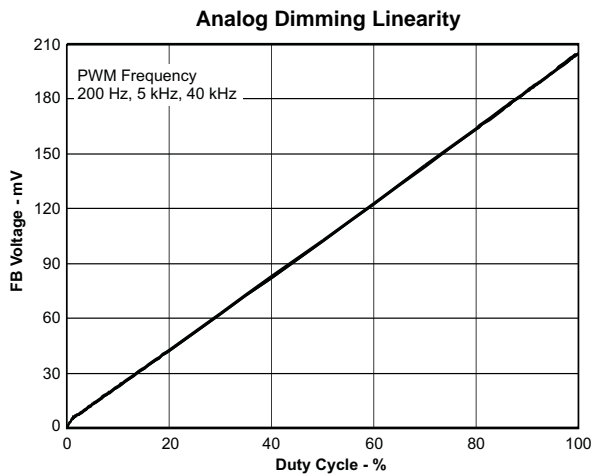

Figure 11.

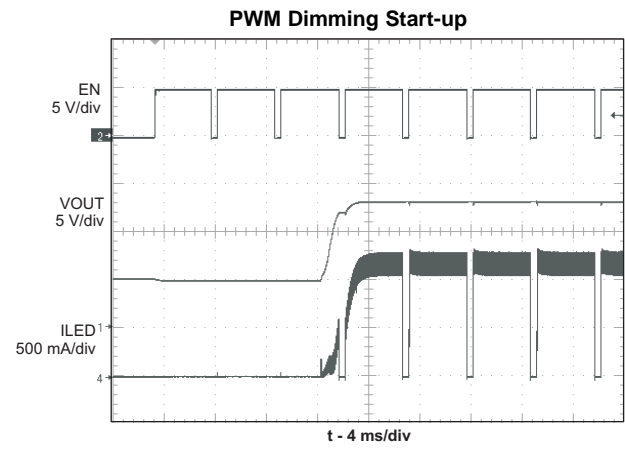

Figure 12.

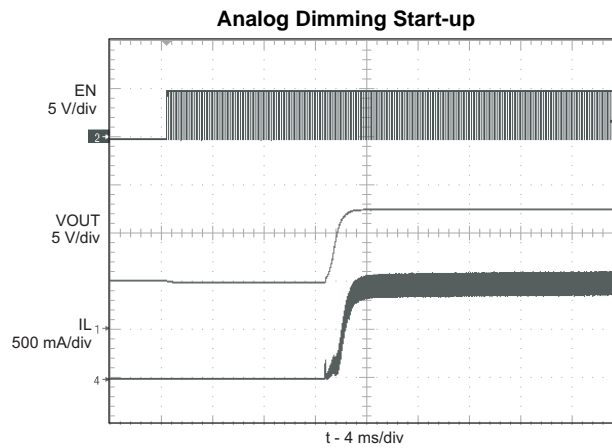

Figure 13.

## DETAILED DESCRIPTION

### OPERATION

The TPS61500 integrates a 3-A/40-V low side switch FET for driving up to 10 high brightness LEDs in series. The device regulates the FB pin voltage at 200-mV with current mode PWM (pulse width modulation) control, and the LED current is sensed through a low value resistor in series with LEDs.

The PWM control circuitry turns on the switch at the beginning of each switching cycle. The input voltage is applied across the inductor and stores the energy as inductor current ramps up. During this portion of the switching cycle, the load current is provided by the output capacitor. When the inductor current rises to the threshold set by the error amplifier output, the power switch turns off and the external Schottky diode is forward biased. The inductor transfers stored energy to replenish the output capacitor and supply the load current. This operation repeats each switching cycle. As shown in the block diagram, the duty cycle of the converter is determined by the PWM control comparator which compares the error amplifier output and the current signal. The switching frequency is programmed by the external resistor.

A ramp signal from the oscillator is added to the current ramp. This slope compensation is necessary to avoid sub-harmonic oscillation that is intrinsic to the current mode control at duty cycle higher than 50%. The feedback loop regulates the FB pin to a reference voltage through an error amplifier. The output of the error amplifier is connected to the COMP pin. An external compensation network is connected to the COMP pin to optimize the feedback loop for stability and transient response.

### SWITCHING FREQUENCY

The switch frequency is determined by a resistor connected to the FREQ pin of the TPS61500. Do not leave this pin open. A resistor must always be connected for proper operation. See [Table 1](#) and [Figure 14](#) for resistor values and corresponding frequencies.

**Table 1. Switching Frequency vs External Resistor**

R4 (k $\Omega$ )	f <sub>sw</sub> (kHz)
443	240
256	400
176	600
80	1200
51	2000

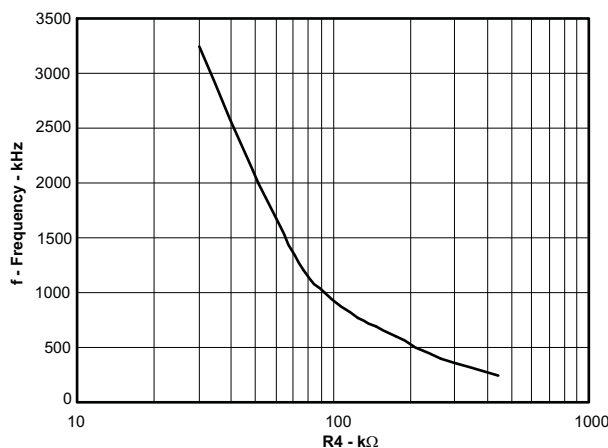

**Figure 14. Switching Frequency vs External Resistor**

Increasing switching frequency reduces the value of external capacitors and inductors, but also reduces the power conversion efficiency. The user should set the frequency for compromise between efficiency and solution size.

## SOFT START

The TPS61500 has a built-in soft start circuit which significantly reduces the start-up current spike and output voltage overshoot. When the IC is enabled, an internal bias current (6- $\mu$ A typically) charges a capacitor (C3) on the SS pin. The voltage at the capacitor clamps the output of the internal error amplifier that determines the duty cycle of PWM control, thereby the input inrush current is eliminated. Once the capacitor reaches 1.8-V, the soft start cycle is completed and the soft start voltage no longer clamps the error amplifier output. Refer to [Figure 12](#) and [Figure 13](#) for the soft start waveform. A 47-nF capacitor eliminates the output overshoot and reduces the peak inductor current for most applications.

When the EN is pulled low for 10-ms, the IC enters shutdown and the SS capacitor discharges through a 5k $\Omega$  resistor for the next soft start.

## ENABLE AND THERMAL SHUTDOWN

The TPS61500 enters shutdown when the EN voltage is less than 0.4-V for more than 10-ms. In shutdown, the input supply current for the device is less than 1.5 $\mu$ A (max). The EN pin has an internal 800-k $\Omega$  pull down resistor to disable the device when it is floating.

An internal thermal shutdown turns off the device when the typical junction temperature of 160°C is exceeded. The IC restarts when the junction temperature drops by 15°C.

## UNDER VOLTAGE LOCKOUT (UVLO)

An under voltage lockout prevents mis-operation of the device at input voltages below typical 2.5V. When the input voltage is below the under voltage threshold, the device remains off and the internal switch FET is turned off. The under voltage lockout threshold is set below minimum operating voltage of 2.9V to avoid any transient VIN dip triggering the UVLO and causing the device to reset. For the input voltages between UVLO threshold and 2.9V, the device maintains its operation, but the specifications are not ensured.

## OVER VOLTAGE PROTECTION

When the FB pin is shorted to ground or an LED fails open circuit, the output voltage can increase to potentially damaging voltages. To prevent the IC and the output capacitor from exceeding the maximum voltage rating, utilize the OVP pin with an external resistor divider to program an OVP threshold, as shown in the typical application. The OVP pin is set at 1.229-V, and the OVP threshold should be higher than the normal operating output voltage.

## APPLICATION INFORMATION

### PROGRAMMING THE OVERVOLTAGE PROTECTION

Select the values of R1 and R2 according to [Equation 1](#).

$$V_{\text{OVP}} = 1.229 \text{ V} \times \left( \frac{R1}{R2} + 1 \right) \quad (1)$$

For example, the total forward voltage of four 3-W LED is 14V, then use R1 of 120k and R2 of 10k to program the threshold of 16V. In the OVP mode, IC regulates the output voltage at the OVP threshold.

When the fault is clear and the OVP pin voltage falls 40-mV below 1.229V, IC resumes the output regulation for LED current.

### PROGRAMMING THE LED CURRENT

LED current can be determined by the value of the feedback resistor R3 and the FB pin regulation voltage of 200-mV as shown in [Equation 2](#):

$$I_{\text{LED}} = \frac{V_{\text{FB}}}{R3} \quad (2)$$

The output current tolerance depends on the FB accuracy and the current sensor resistor accuracy.

### IMPLEMENTING DIMMING

Two LED current dimming methods are provided.

1. Floating the DIMC pin, an external PWM signal via the EN pin, providing pure PWM dimming method.
2. Connecting a capacitor larger than 100-nF to the DIMC pin, an external PWM signal via the EN pin, providing analog dimming.

#### PWM Dimming Method

LED brightness is controlled by peak LED current and duty cycle of external PWM signal. See [Figure 2](#), [Figure 8](#) and [Figure 9](#) for the PWM dimming operating and linearity. Additional external switch FETs connect/disconnect LED string during PWM on/off period, shown in the typical application. Simultaneously, the TPS61500 samples and holds the COMP voltage to speed up LED current regulation during the on period. As the IC and the external switch FETs need several hundred microseconds to regulate the LED current, the frequency and minimum duty cycle of the PWM signal are application dependent. For example, 2% is the minimum duty cycle for a 200Hz PWM signal.

The PWM dimming method offers better control of color because current through LED is kept constant each cycle.

#### Analog Dimming Method

When capacitor C5 is connected to the DIMC pin, the FB regulation voltage is scaled proportional to the external PWM signal's duty cycle; therefore, it achieves LED brightness change, shown in [Figure 1](#). The relationship between the duty cycle and LED current is given by [Equation 3](#):

$$I_{\text{LED}} = \frac{V_{\text{FB}}}{R3} \times \text{Duty} \quad (3)$$

where, duty is the duty cycle of the PWM signal.

The IC chops up the internal 200mV reference voltage at the duty cycle of the PWM signal. The pulsed reference voltage is then filtered by a low pass filter that is composed of an internal 25-kΩ resistor and the external capacitor C5. The output of the filter is connected to the error amplifier as the reference voltage for the FB pin. Therefore, although a PWM signal is used for brightness dimming, only the LED DC current is modulated. This eliminates the audible noise which often occurs when the LED current is pulsed during PWM dimming. Unlike other methods for filtering the PWM signal, the TPS61500's analog dimming method is independent of the PWM logic voltage level which often has large variations.

For optimum performance, the value of C5 is recommended as large as possible to provide adequate filtering for the PWM frequency. For example, when the PWM frequency is 5-kHz, C5 equal to 1-μF is sufficient.

## COMPUTING THE MAXIMUM OUTPUT CURRENT

The over-current limit in a boost converter limits the maximum input current and thus maximum input power for a given input voltage. Maximum output power is less than maximum input power due to power conversion losses. Therefore, the current limit setting, input voltage, output voltage and efficiency can all change maximum current output. The current limit clamps the peak inductor current, therefore the ripple has to be subtracted to derive maximum DC current. The ripple current is a function of switching frequency, inductor value and duty cycle. The following equations take into account of all the above factors for maximum output current calculation.

$$I_p = \frac{1}{L \times F_s \times \left( \frac{1}{V_{out} + V_f - V_{in}} + \frac{1}{V_{in}} \right)} \quad (4)$$

Where

$I_p$  = inductor peak to peak ripple

$L$  = inductor value

$V_f$  = Schottky diode forward voltage

$F_s$  = switching frequency

$V_{out}$  = output voltage =  $\sum V_{LEDs} + V_{REF}$

$$I_{LED\_max} = \frac{V_{in} \times (I_{lim} - I_p/2) \times \eta}{V_{out}} \quad (5)$$

Where

$I_{LED\_max}$  = maximum LED current from the boost converter

$I_{lim}$  = over current limit

$V_{LED}$  = LED forward voltage at  $I_{LED}$

$\eta$  = efficiency estimate based on similar applications

For instance, when  $V_{IN}$  is 12-V, 8 LEDs output is equivalent to  $V_{out}$  of 24V, the inductor is 10-μH, the Schottky forward voltage is 0.4-V and the switching frequency is 1.2-MHz; then the maximum output current is around 1-A in typical condition.

## SELECTING THE INDUCTOR

The selection of the inductor affects steady state operation as well as transient behavior and loop stability. These factors make it the most important component in power regulator design. There are three important inductor specifications, inductor value, DC resistance and saturation current. Considering inductor value alone is not enough.

Inductor values can have  $\pm 20\%$  tolerance with no current bias. When the inductor current approaches saturation level, its inductance can fall to some percentage of its 0-A value depending on how the inductor vendor defines saturation current.

Using an inductor with a smaller inductance value forces discontinuous PWM where the inductor current ramps down to zero before the end of each switching cycle. This reduces the boost converter's maximum output current, causes large input voltage ripple and reduces efficiency. In general, large inductance value provides much more output and higher conversion efficiency. Small inductance value can give better the load transient response. For these reasons, a 4.7μH to 22μH inductor value range is recommended. [Table 2](#) lists the recommended inductor for the TPS61500.

Meanwhile, the TPS61500 can program the switching frequency. Normally, small inductance value is suitable for high frequency and vice versa. The device has built-in slope compensation to avoid sub-harmonic oscillation associated with current mode control. If the inductor value is lower than 4.7μH, the slope compensation may not be adequate, and the loop can be unstable. Therefore, customers need to verify the inductor in their application if it is different from the recommended values.

**Table 2. Recommended Inductors for TPS61500**

Part Number	L (μH)	DCR Max (mΩ)	Saturation Current (A)	Size (L x W x H mm)	VENDOR
D104C2	10	44	3.6	10.4 x 10.4 x 4.8	TOKO
VLF10040	15	42	3.1	10.0 x 9.7 x 4.0	TDK
CDRH105RNP	22	61	2.9	10.5 x 10.3 x 5.1	Sumida
MSS1038	15	50	3.8	10.0 x 10.2 x 3.8	Coilcraft

## SELECTING THE SCHOTTKY DIODE

The high switching frequency of the TPS61500 demands a high-speed rectification for optimum efficiency. Ensure that the diode's average and peak current rating exceed the average output current and peak inductor current. In addition, the diode's reverse breakdown voltage must exceed the switch FET rating voltage of 40V. So, the VISHAY SS3P6L-E3/86A is recommended for TPS61500. The power dissipation of the diode's package must be larger than the  $I_{OUT(max)} \times V_D$ .

## SELECTING THE COMPENSATION CAPACITOR AND RESISTOR

The TPS61500 has an external compensation, COMP pin, which allows the loop response to be optimized for each application. The COMP pin is the output of the internal error amplifier. An external ceramic capacitors C4 are connected to COMP pin to stabilize the feedback loop. Use 470-nF for C4.

## SELECTING THE INPUT AND OUTPUT CAPACITOR

The output capacitor is mainly selected to meet the requirements for the output ripple and loop stability. This ripple voltage is related to the capacitor's capacitance and its equivalent series resistance (ESR). Assuming a capacitor with zero ESR, the minimum capacitance needed for a given ripple can be calculated by

$$C_{out} = \frac{(V_{out} - V_{in})_{out}}{V_{out} \times F_s \times V_{ripple}} \quad (6)$$

where,  $V_{ripple}$  = peak to peak output ripple. The additional output ripple component caused by ESR is calculated using:

$$V_{ripple\_ESR} = I_{out} \times R_{ESR} \quad (7)$$

Due to its low ESR,  $V_{ripple\_ESR}$  can be neglected for ceramic capacitors, but must be considered if tantalum or electrolytic capacitors are used.

Care must be taken when evaluating a ceramic capacitor's derating under dc bias, aging and AC signal. For example, larger form factor capacitors (in 1206 size) have their self resonant frequencies in the range of the switching frequency. So the effective capacitance is significantly lower. The DC bias can also significantly reduce capacitance. Ceramic capacitors can lose as much as 50% of its capacitance at its rated voltage. Therefore, almost leave margin on the voltage rating to ensure adequate capacitance at the required output voltage.

The capacitor in the range of 1μF to 4.7μF is recommended for input side. The output requires a capacitor in the range of 1μF to 10μF. The output capacitor affects the loop stability of the boost regulator. If the output capacitor is below the range, the boost regulator can potentially become unstable.

The popular vendors for high value ceramic capacitors are:

**TDK** (<http://www.component.tdk.com/components.php>)

**Murata** (<http://www.murata.com/cap/index.html>)



**PACKAGING INFORMATION**

Orderable Device	Status <sup>(1)</sup>	Package Type	Package Drawing	Pins	Package Qty	Eco Plan <sup>(2)</sup>	Lead/Ball Finish	MSL Peak Temp <sup>(3)</sup>
TPS61500PWP	ACTIVE	HTSSOP	PWP	14	90	Green (RoHS & no Sb/Br)	CU NIPDAU	Level-2-260C-1 YEAR
TPS61500PWPR	ACTIVE	HTSSOP	PWP	14	2000	Green (RoHS & no Sb/Br)	CU NIPDAU	Level-2-260C-1 YEAR

<sup>(1)</sup> The marketing status values are defined as follows:

**ACTIVE:** Product device recommended for new designs.

**LIFEBUY:** TI has announced that the device will be discontinued, and a lifetime-buy period is in effect.

**NRND:** Not recommended for new designs. Device is in production to support existing customers, but TI does not recommend using this part in a new design.

**PREVIEW:** Device has been announced but is not in production. Samples may or may not be available.

**OBsolete:** TI has discontinued the production of the device.

<sup>(2)</sup> Eco Plan - The planned eco-friendly classification: Pb-Free (RoHS), Pb-Free (RoHS Exempt), or Green (RoHS & no Sb/Br) - please check <http://www.ti.com/productcontent> for the latest availability information and additional product content details.

**TBD:** The Pb-Free/Green conversion plan has not been defined.

**Pb-Free (RoHS):** TI's terms "Lead-Free" or "Pb-Free" mean semiconductor products that are compatible with the current RoHS requirements for all 6 substances, including the requirement that lead not exceed 0.1% by weight in homogeneous materials. Where designed to be soldered at high temperatures, TI Pb-Free products are suitable for use in specified lead-free processes.

**Pb-Free (RoHS Exempt):** This component has a RoHS exemption for either 1) lead-based flip-chip solder bumps used between the die and package, or 2) lead-based die adhesive used between the die and leadframe. The component is otherwise considered Pb-Free (RoHS compatible) as defined above.

**Green (RoHS & no Sb/Br):** TI defines "Green" to mean Pb-Free (RoHS compatible), and free of Bromine (Br) and Antimony (Sb) based flame retardants (Br or Sb do not exceed 0.1% by weight in homogeneous material)

<sup>(3)</sup> MSL, Peak Temp. -- The Moisture Sensitivity Level rating according to the JEDEC industry standard classifications, and peak solder temperature.

**Important Information and Disclaimer:**The information provided on this page represents TI's knowledge and belief as of the date that it is provided. TI bases its knowledge and belief on information provided by third parties, and makes no representation or warranty as to the accuracy of such information. Efforts are underway to better integrate information from third parties. TI has taken and continues to take reasonable steps to provide representative and accurate information but may not have conducted destructive testing or chemical analysis on incoming materials and chemicals. TI and TI suppliers consider certain information to be proprietary, and thus CAS numbers and other limited information may not be available for release.

In no event shall TI's liability arising out of such information exceed the total purchase price of the TI part(s) at issue in this document sold by TI to Customer on an annual basis.

## TAPE AND REEL INFORMATION

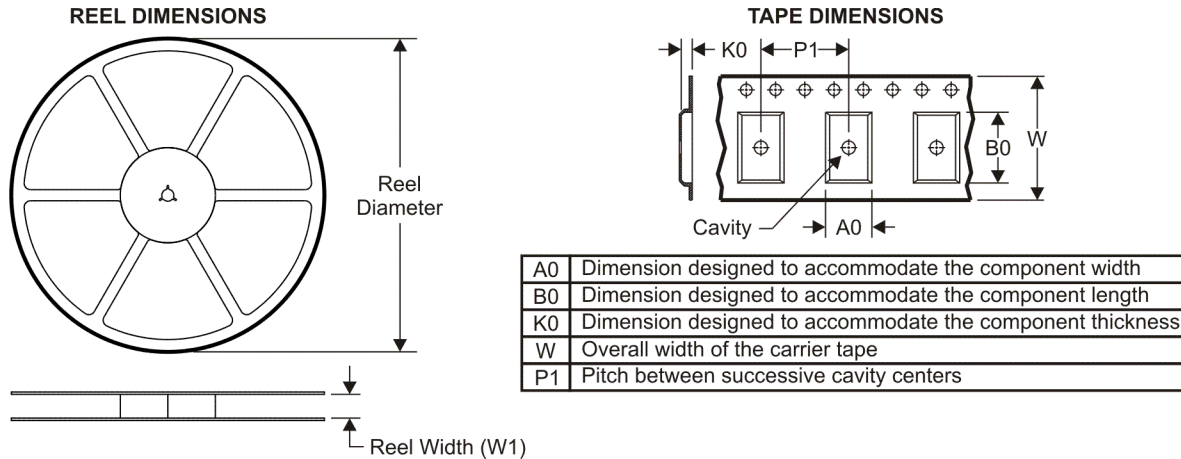

### QUADRANT ASSIGNMENTS FOR PIN 1 ORIENTATION IN TAPE

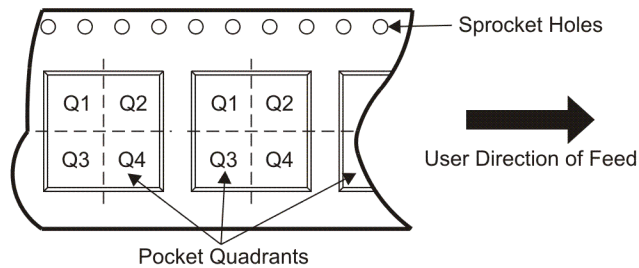

\*All dimensions are nominal

Device	Package Type	Package Drawing	Pins	SPQ	Reel Diameter (mm)	Reel Width W1 (mm)	A0 (mm)	B0 (mm)	K0 (mm)	P1 (mm)	W (mm)	Pin1 Quadrant
TPS61500PWPR	HTSSOP	PWP	14	2000	330.0	12.4	6.9	5.6	1.6	8.0	12.0	Q1

TAPE AND REEL BOX DIMENSIONS



\*All dimensions are nominal

Device	Package Type	Package Drawing	Pins	SPQ	Length (mm)	Width (mm)	Height (mm)
TPS61500PWPR	HTSSOP	PWP	14	2000	346.0	346.0	29.0

# MECHANICAL DATA

PWP (R-PDSO-G\*\*) 20 PIN SHOWN

PowerPAD™ PLASTIC SMALL-OUTLINE PACKAGE

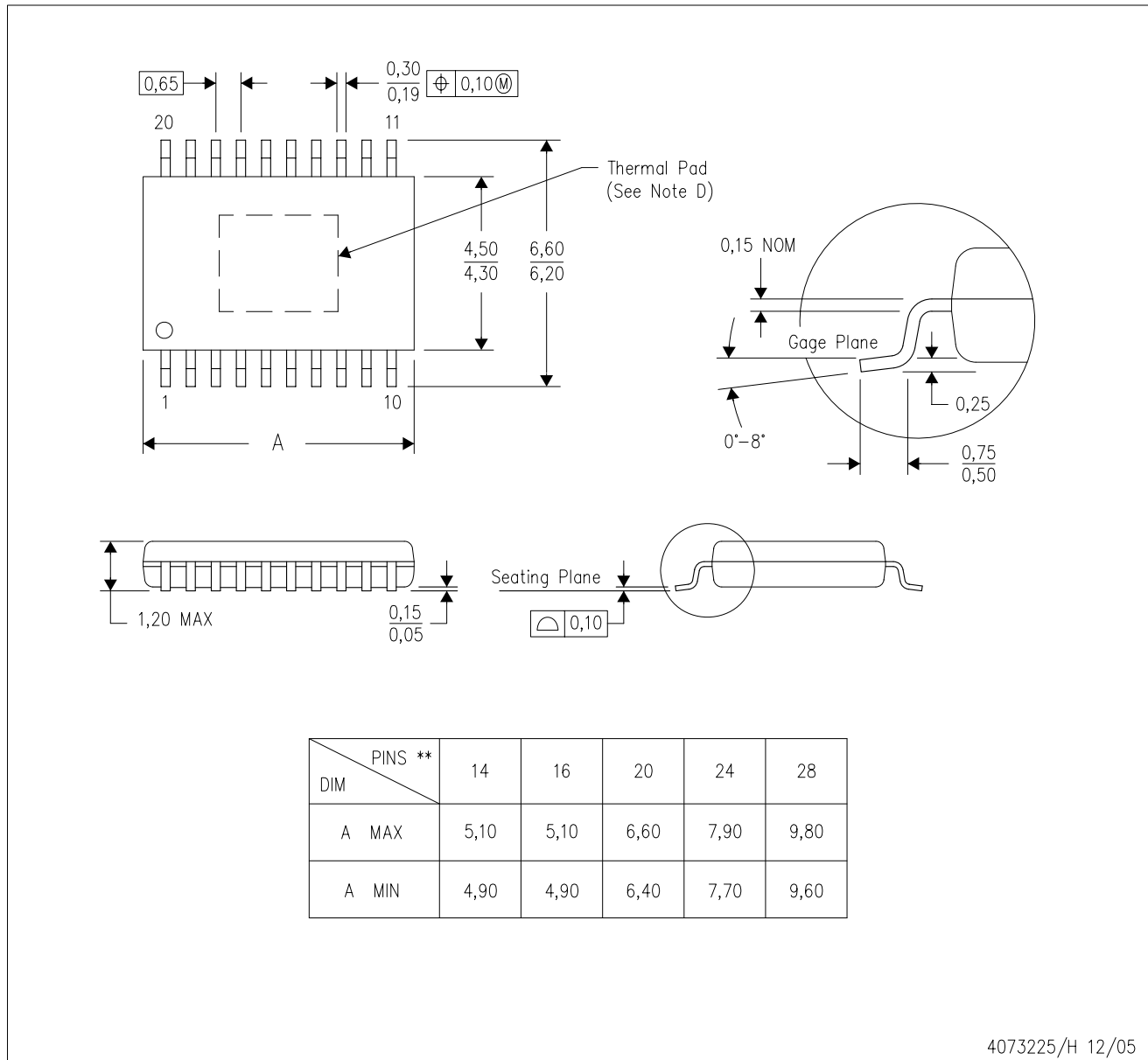

4073225/H 12/05

- NOTES:
- A. All linear dimensions are in millimeters.
  - B. This drawing is subject to change without notice.
  - C. Body dimensions do not include mold flash or protrusions. Mold flash and protrusion shall not exceed 0.15 per side.
  - D. This package is designed to be soldered to a thermal pad on the board. Refer to Technical Brief, PowerPad Thermally Enhanced Package, Texas Instruments Literature No. SLMA002 for information regarding recommended board layout. This document is available at [www.ti.com](http://www.ti.com) <<http://www.ti.com>>.
  - E. Falls within JEDEC MO-153

PowerPAD is a trademark of Texas Instruments.

**THERMAL INFORMATION**

This PowerPAD™ package incorporates an exposed thermal pad that is designed to be attached to a printed circuit board (PCB). The thermal pad must be soldered directly to the PCB. After soldering, the PCB can be used as a heatsink. In addition, through the use of thermal vias, the thermal pad can be attached directly to the appropriate copper plane shown in the electrical schematic for the device, or alternatively, can be attached to a special heatsink structure designed into the PCB. This design optimizes the heat transfer from the integrated circuit (IC).

For additional information on the PowerPAD package and how to take advantage of its heat dissipating abilities, refer to Technical Brief, PowerPAD Thermally Enhanced Package, Texas Instruments Literature No. SLMA002 and Application Brief, PowerPAD Made Easy, Texas Instruments Literature No. SLMA004. Both documents are available at [www.ti.com](http://www.ti.com).

The exposed thermal pad dimensions for this package are shown in the following illustration.

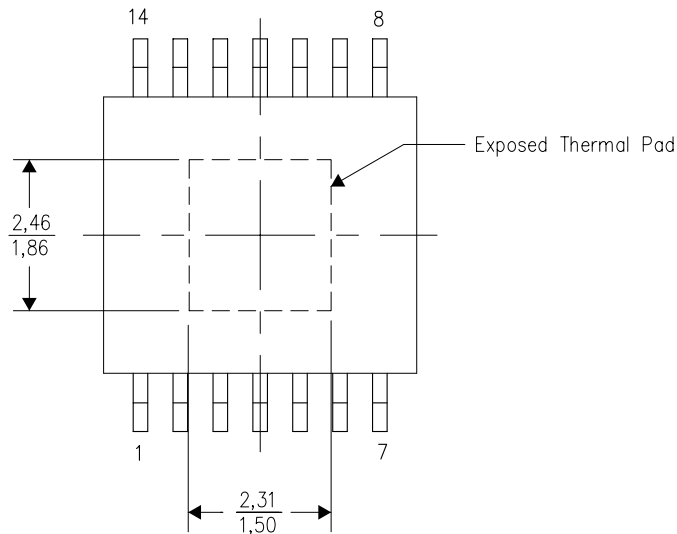

Top View

NOTE: All linear dimensions are in millimeters

Exposed Thermal Pad Dimensions

## PWP (R-PDSO-G14) PowerPAD™

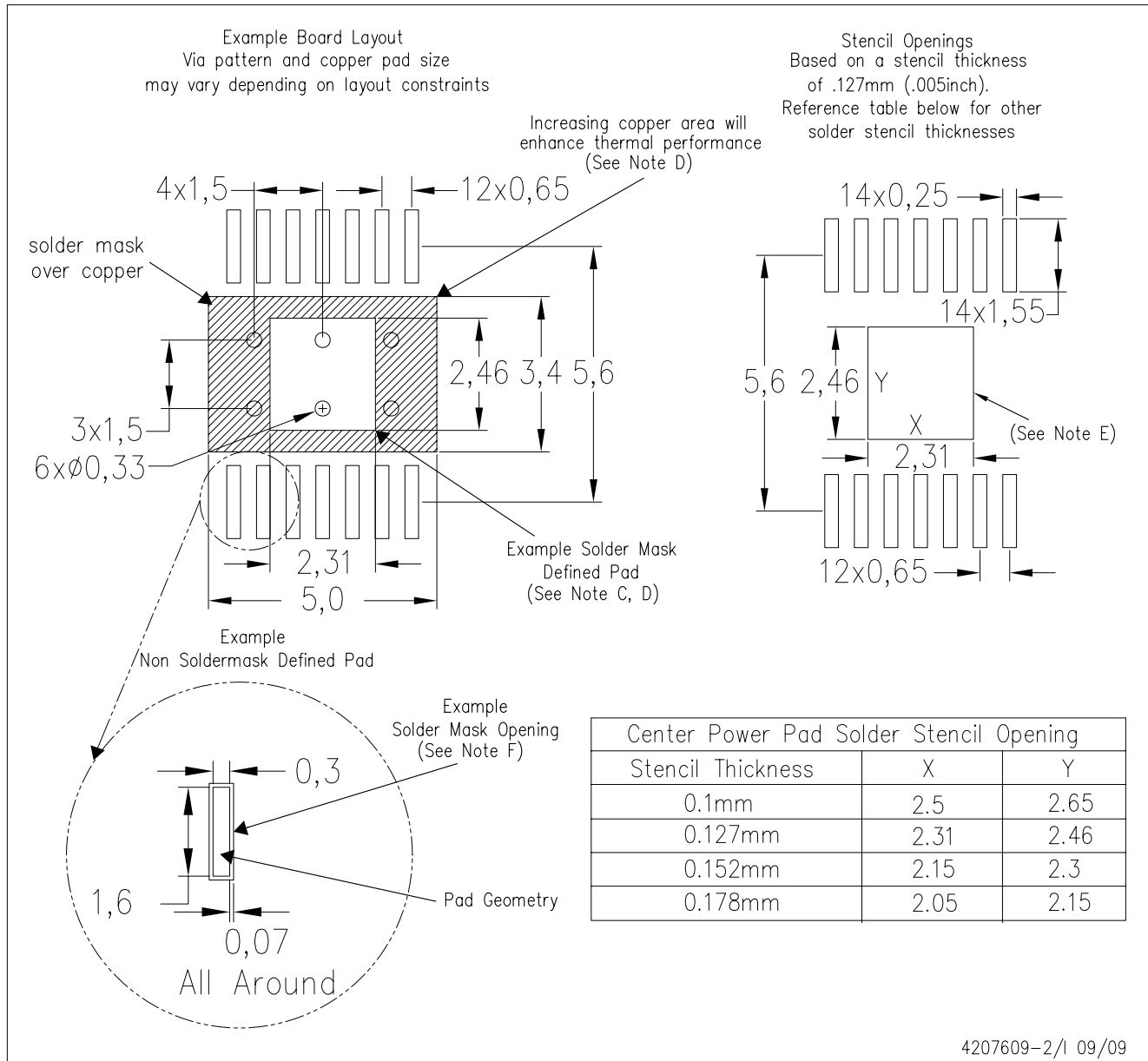

- NOTES:
- All linear dimensions are in millimeters.
  - This drawing is subject to change without notice.
  - Customers should place a note on the circuit board fabrication drawing not to alter the center solder mask defined pad.
  - This package is designed to be soldered to a thermal pad on the board. Refer to Technical Brief, PowerPAD Thermally Enhanced Package, Texas Instruments Literature No. SLMA002, SLMA004, and also the Product Data Sheets for specific thermal information, via requirements, and recommended board layout. These documents are available at [www.ti.com](http://www.ti.com) <<http://www.ti.com>>. Publication IPC-7351 is recommended for alternate designs.
  - Laser cutting apertures with trapezoidal walls and also rounding corners will offer better paste release. Customers should contact their board assembly site for stencil design recommendations. Example stencil design based on a 50% volumetric metal load solder paste. Refer to IPC-7525 for other stencil recommendations.
  - Customers should contact their board fabrication site for solder mask tolerances between and around signal pads.

PowerPAD is a trademark of Texas Instruments.

## IMPORTANT NOTICE

Texas Instruments Incorporated and its subsidiaries (TI) reserve the right to make corrections, modifications, enhancements, improvements, and other changes to its products and services at any time and to discontinue any product or service without notice. Customers should obtain the latest relevant information before placing orders and should verify that such information is current and complete. All products are sold subject to TI's terms and conditions of sale supplied at the time of order acknowledgment.

TI warrants performance of its hardware products to the specifications applicable at the time of sale in accordance with TI's standard warranty. Testing and other quality control techniques are used to the extent TI deems necessary to support this warranty. Except where mandated by government requirements, testing of all parameters of each product is not necessarily performed.

TI assumes no liability for applications assistance or customer product design. Customers are responsible for their products and applications using TI components. To minimize the risks associated with customer products and applications, customers should provide adequate design and operating safeguards.

TI does not warrant or represent that any license, either express or implied, is granted under any TI patent right, copyright, mask work right, or other TI intellectual property right relating to any combination, machine, or process in which TI products or services are used. Information published by TI regarding third-party products or services does not constitute a license from TI to use such products or services or a warranty or endorsement thereof. Use of such information may require a license from a third party under the patents or other intellectual property of the third party, or a license from TI under the patents or other intellectual property of TI.

Reproduction of TI information in TI data books or data sheets is permissible only if reproduction is without alteration and is accompanied by all associated warranties, conditions, limitations, and notices. Reproduction of this information with alteration is an unfair and deceptive business practice. TI is not responsible or liable for such altered documentation. Information of third parties may be subject to additional restrictions.

Resale of TI products or services with statements different from or beyond the parameters stated by TI for that product or service voids all express and any implied warranties for the associated TI product or service and is an unfair and deceptive business practice. TI is not responsible or liable for any such statements.

TI products are not authorized for use in safety-critical applications (such as life support) where a failure of the TI product would reasonably be expected to cause severe personal injury or death, unless officers of the parties have executed an agreement specifically governing such use. Buyers represent that they have all necessary expertise in the safety and regulatory ramifications of their applications, and acknowledge and agree that they are solely responsible for all legal, regulatory and safety-related requirements concerning their products and any use of TI products in such safety-critical applications, notwithstanding any applications-related information or support that may be provided by TI. Further, Buyers must fully indemnify TI and its representatives against any damages arising out of the use of TI products in such safety-critical applications.

TI products are neither designed nor intended for use in military/aerospace applications or environments unless the TI products are specifically designated by TI as military-grade or "enhanced plastic." Only products designated by TI as military-grade meet military specifications. Buyers acknowledge and agree that any such use of TI products which TI has not designated as military-grade is solely at the Buyer's risk, and that they are solely responsible for compliance with all legal and regulatory requirements in connection with such use.

TI products are neither designed nor intended for use in automotive applications or environments unless the specific TI products are designated by TI as compliant with ISO/TS 16949 requirements. Buyers acknowledge and agree that, if they use any non-designated products in automotive applications, TI will not be responsible for any failure to meet such requirements.

Following are URLs where you can obtain information on other Texas Instruments products and application solutions:

<b>Products</b>		<b>Applications</b>	
Amplifiers	<a href="http://amplifier.ti.com">amplifier.ti.com</a>	Audio	<a href="http://www.ti.com/audio">www.ti.com/audio</a>
Data Converters	<a href="http://dataconverter.ti.com">dataconverter.ti.com</a>	Automotive	<a href="http://www.ti.com/automotive">www.ti.com/automotive</a>
DLP® Products	<a href="http://www.dlp.com">www.dlp.com</a>	Communications and Telecom	<a href="http://www.ti.com/communications">www.ti.com/communications</a>
DSP	<a href="http://dsp.ti.com">dsp.ti.com</a>	Computers and Peripherals	<a href="http://www.ti.com/computers">www.ti.com/computers</a>
Clocks and Timers	<a href="http://www.ti.com/clocks">www.ti.com/clocks</a>	Consumer Electronics	<a href="http://www.ti.com/consumer-apps">www.ti.com/consumer-apps</a>
Interface	<a href="http://interface.ti.com">interface.ti.com</a>	Energy	<a href="http://www.ti.com/energy">www.ti.com/energy</a>
Logic	<a href="http://logic.ti.com">logic.ti.com</a>	Industrial	<a href="http://www.ti.com/industrial">www.ti.com/industrial</a>
Power Mgmt	<a href="http://power.ti.com">power.ti.com</a>	Medical	<a href="http://www.ti.com/medical">www.ti.com/medical</a>
Microcontrollers	<a href="http://microcontroller.ti.com">microcontroller.ti.com</a>	Security	<a href="http://www.ti.com/security">www.ti.com/security</a>
RFID	<a href="http://www.ti-rfid.com">www.ti-rfid.com</a>	Space, Avionics & Defense	<a href="http://www.ti.com/space-avionics-defense">www.ti.com/space-avionics-defense</a>
RF/IF and ZigBee® Solutions	<a href="http://www.ti.com/lprf">www.ti.com/lprf</a>	Video and Imaging	<a href="http://www.ti.com/video">www.ti.com/video</a>
		Wireless	<a href="http://www.ti.com/wireless-apps">www.ti.com/wireless-apps</a>